

PATTERSON-KELLEY CO.

P-K MACH 'n' ROLL MnR1050

DES. **J. ROBERSON**

JOB NO. **11-1535**

DATE **12/4/15**

SHEET

1

OF **2** SHEETS

SEISMIC ANCHORAGE

SLAB ON GRADE

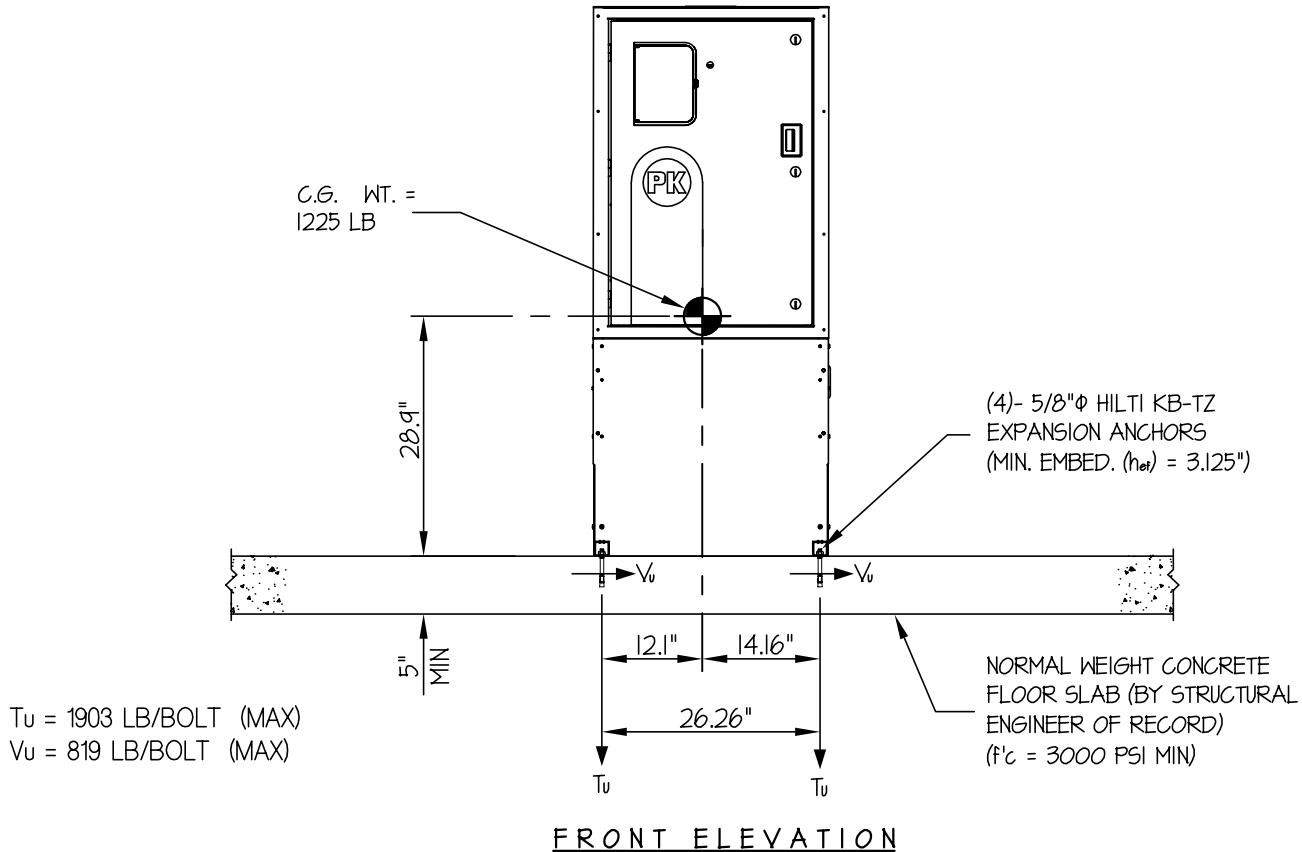

T_u = 1903 LB/BOLT (MAX)
 V_u = 819 LB/BOLT (MAX)

NOTES:

- FORCES ARE DETERMINED PER 2013 CALIFORNIA BUILDING CODE AND ASCE 7-10**
STRENGTH DESIGN IS USED. ($S_{Ds} = 2.20$, $a_p = 1.0$, $l_p = 1.5$, $R_p = 2.5$, $\Omega_0 = 2.5$, $z/h = 0$)
HORIZONTAL FORCE (E_h) = $0.99 W_p$
HORIZONTAL FORCE (E_{mh}) = $2.48 W_p$ (FOR CONCRETE ANCHORAGE)
VERTICAL FORCE (E_v) = $0.44 W_p$
- CENTER OF GRAVITY (C.G.) AND WEIGHT ARE THE GOVERNING PARAMETERS FOR DESIGN. THESE CALCULATIONS ENCOMPASS ALL WEIGHTS UP TO THE MAXIMUM WEIGHT SHOWN.
- STRUCTURAL ENGINEER OF RECORD FOR THE BUILDING SHALL PROVIDE SUPPORT STRUCTURE DESIGNED TO SUPPORT WEIGHTS AND FORCES SHOWN IN COMBINATION WITH ALL OTHER LOADS THAT MAY BE PRESENT.



PATTERSON-KELLEY CO.

DES. **J. ROBERSON**

SHEET

2

JOB NO. **11-1535**

P-K MACH 'n' ROLL MnR1050

DATE **12/4/15**

OF **2** SHEETS

SEISMIC ANCHORAGE

SLAB ON GRADE

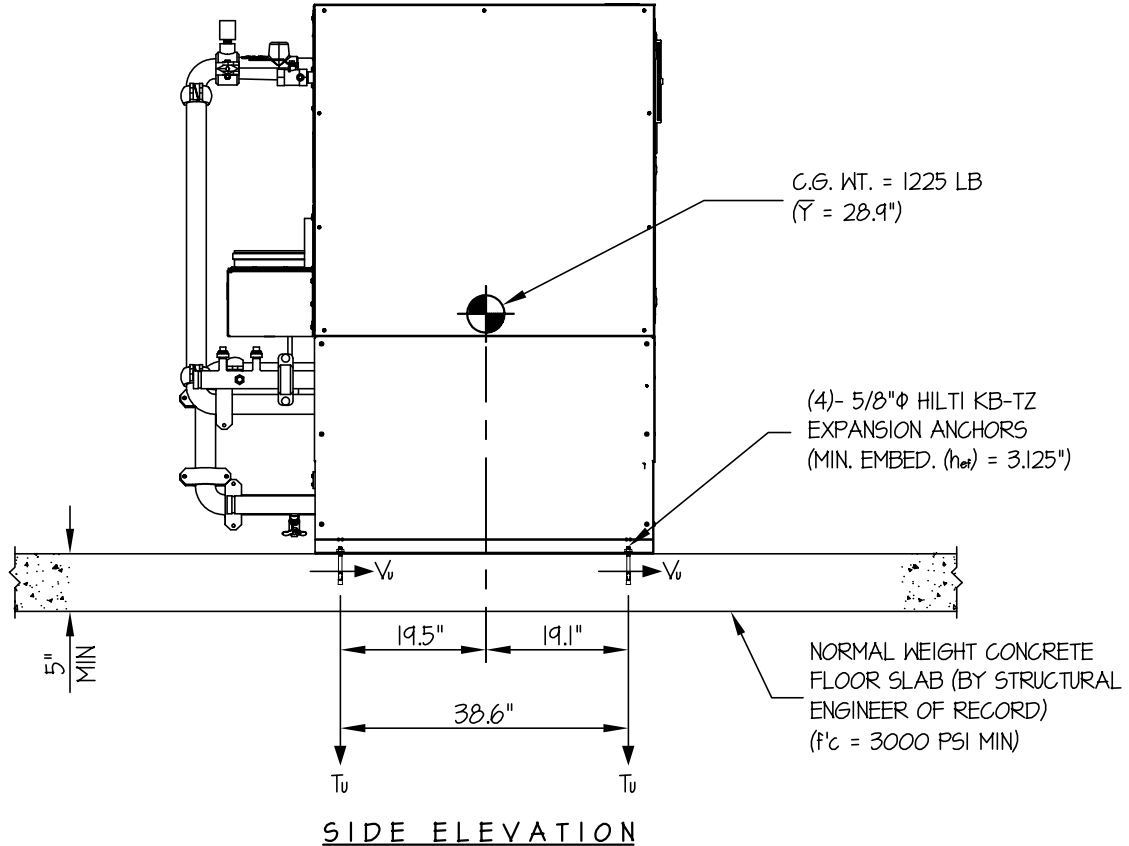

LOADS: PER 2013 CALIFORNIA BUILDING CODE AND ASCE 7-10.

STRENGTH DESIGN IS USED ($S_{Ds} = 2.20$, $a_p = 1.0$, $I_p = 1.5$, $R_p = 2.5$, $\Omega_0 = 2.5$, $z/h = 0$)

WEIGHT = 1225 LB

HORIZONTAL FORCE (E_{mh}) = $2.48 W_p = 3038$ LB

VERTICAL FORCE (E_v) = $0.44 W_p = 539$ LB

BOLT FORCES:

BOLT SPECS: 5/8" ϕ HILTI KB-TZ

$\phi T = 0.75 \phi N_n = 2508$ LB/BOLT (TENSION)

$\phi V = \phi V_n = 4940$ LB/BOLT (SHEAR)

TENSION (T)

$$T_{u \text{ MAXIMUM}} = \left[\frac{3038\#(28.9")(14.16")}{1 \text{ BOLT } (38.6")(26.26")} \times (0.3) \right] + \frac{3038\#(28.9")(19.5")}{1 \text{ BOLT } (26.26")(38.6")} - \frac{(1225\#(0.9) - 539\#)(14.16")(19.5")}{1 \text{ BOLT } (26.26")(38.6")} = 1903 \text{ LB/BOLT (MAX)}$$

(HORIZ - FRONT TO BACK) (HORIZ - SIDE TO SIDE) (WEIGHT(0.9) - E_v)

SHEAR (V)

$$V_{u \text{ MAXIMUM}} = \frac{3038\#(14.16")}{2 \text{ BOLTS } (26.26")} = 819 \text{ LB/BOLT (MAX)}$$

UNITY CHECK:

$$\left(\frac{T_u}{\phi T} \right) + \left(\frac{V_u}{\phi V} \right) \leq 1.2 \quad \left(\frac{1903}{2508} \right) + \left(\frac{819}{4940} \right) = 0.93 \leq 1.2 \quad \therefore \text{O.K.}$$

PATTERSON-KELLEY CO.

P-K MACH 'n' ROLL MnR1050

DES. **J. ROBERSON**

JOB NO. **11-1535**

DATE **12/4/15**

SHEET

1

OF **2** SHEETS

SEISMIC ANCHORAGE

UPPER FLOOR

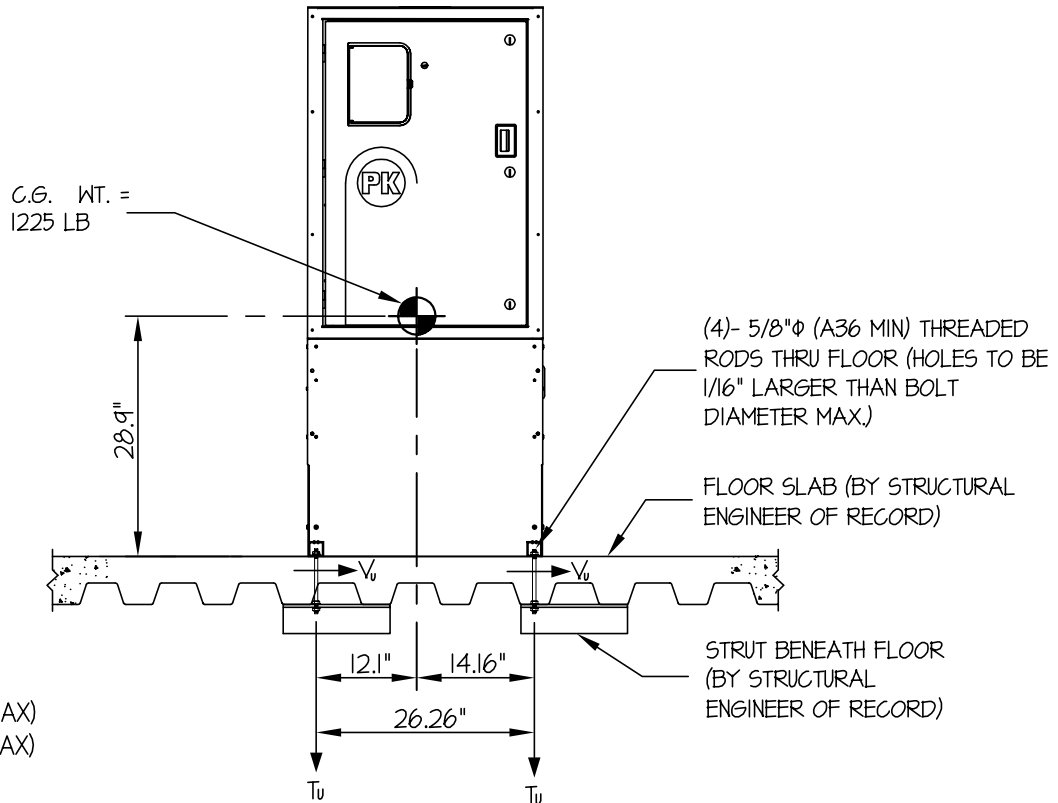

FRONT ELEVATION

NOTES:

1. FORCES ARE DETERMINED PER 2013 CALIFORNIA BUILDING CODE AND ASCE 7-10.

STRENGTH DESIGN IS USED. ($S_Ds = 2.20$, $a_p = 1.0$, $I_p = 1.5$, $R_p = 2.5$, $z/h \leq 1$)

HORIZONTAL FORCE (E_h) = $1.58 W_p$

VERTICAL FORCE (E_v) = $0.44 W_p$

2. CENTER OF GRAVITY (C.G.) AND WEIGHT ARE THE GOVERNING PARAMETERS FOR DESIGN. THESE CALCULATIONS ENCOMPASS ALL WEIGHTS UP TO THE MAXIMUM WEIGHT SHOWN.

3. STRUCTURAL ENGINEER OF RECORD FOR THE BUILDING SHALL PROVIDE SUPPORT STRUCTURE DESIGNED TO SUPPORT WEIGHTS AND FORCES SHOWN IN COMBINATION WITH ALL OTHER LOADS THAT MAY BE PRESENT.



PATTERSON-KELLEY CO.

P-K MACH 'n' ROLL MnR1050

DES. **J. ROBERSON**

JOB NO. **11-1535**

DATE **12/4/15**

SHEET

2

OF **2** SHEETS

SEISMIC ANCHORAGE

UPPER FLOOR

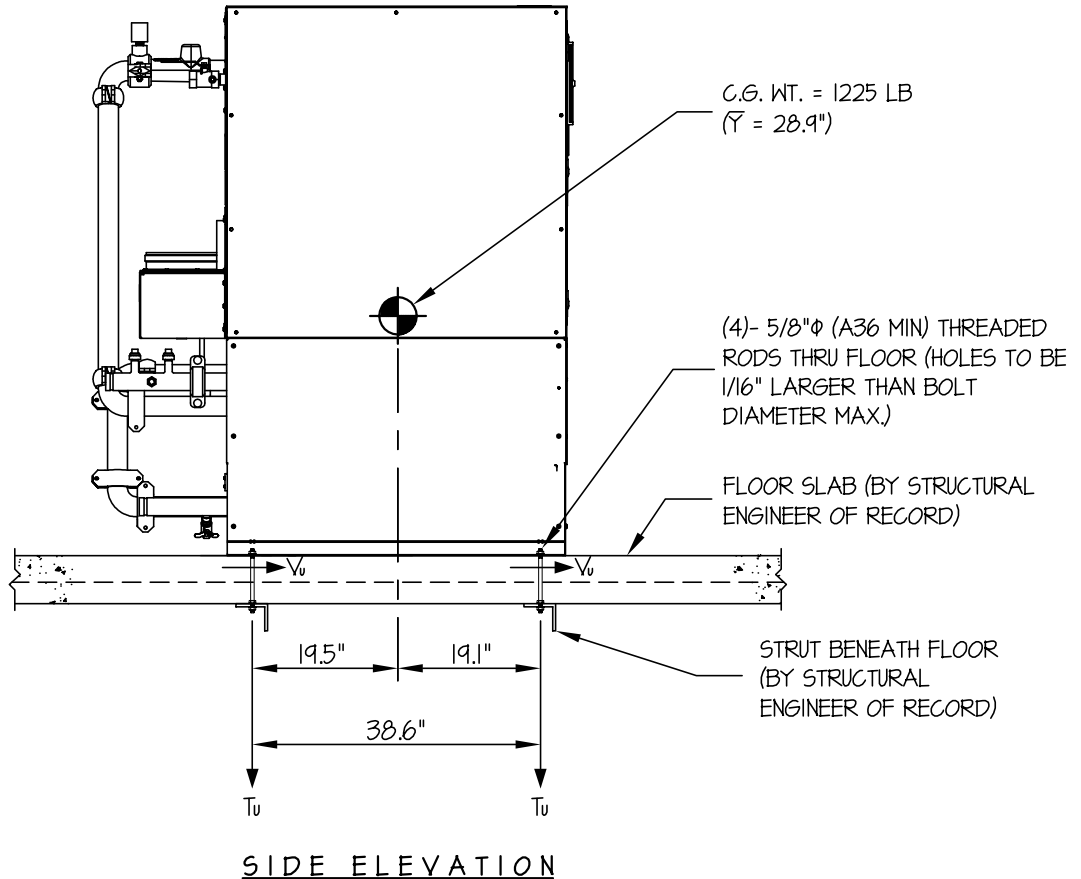

LOADS: PER 2013 CALIFORNIA BUILDING CODE AND ASCE 7-10.

STRENGTH DESIGN IS USED ($S_{ds} = 2.20$, $a_p = 1.0$, $I_p = 15$, $R_p = 2.5$, $z/h \leq 1$)

WEIGHT = 1225 LB

HORIZONTAL FORCE (E_h) = $1.58W_p = 1936$ LB

VERTICAL FORCE (E_v) = $0.44W_p = 539$ LB

BOLT FORCES:

BOLT SPECS: 5/8"φ (A36) THREADED ROD

ΦT = 10,016 LB/BOLT (TENSION)

ΦV = 5342 LB/BOLT (SHEAR)

TENSION (T)

$$T_{U \text{ MAXIMUM}} = \left[\frac{1936\#(28.9'')(14.16'')}{1 \text{ BOLT } (38.6'')(26.26'')} \times (0.3) \right] + \frac{1936\#(28.9'')(19.5'')}{1 \text{ BOLT } (26.26'')(38.6'')} - \frac{(1225\#(0.9) - 539\#)(14.16'')(19.5'')}{1 \text{ BOLT } (26.26'')(38.6'')} = 1157 \text{ LB/BOLT (MAX)}$$

(HORIZ - FRONT TO BACK) (HORIZ - SIDE TO SIDE) (WEIGHT (0.9) - E_v)

SHEAR (V)

$$V_{U \text{ MAXIMUM}} = \frac{1936\#(14.16'')}{2 \text{ BOLTS } (26.26'')} = 522 \text{ LB/BOLT (MAX)}$$